



HECKLER & KOCH

NO COMPROMISE

MP5K

GAS AIRSOFT / cal. 6 mm

powered by **UMAREX**® www.umarex.com

UMAREX HOLDS THE WORLDWIDE EXCLUSIVE
HK-TRADEMARK AND EXTERIOR DESIGN
COPY LICENSE FOR USE WITH THIS PRODUCT,
GRANTED BY HECKLER & KOCH GMBH.



EN Operating instructions 2 - 8

FR Mode d'emploi 16 - 22

DE Bedienungsanleitung 9 - 15

ES Manual de instrucciones 23 - 29



SAFE GUN HANDLING

EN



DESCRIPTION



OPERATION



MAINTENANCE



SAFETY INSTRUCTIONS

You should be fully familiar with the proper and safe handling of your weapon. The basic principles of weapons safety require you to always apply the following rules when handling the firearm.

- Always treat a weapon as if it was loaded.
- Always put the safety of a weapon to “safe” when loading it so that there can be no unintentional discharge.
- Keep your finger away from the trigger. It should be straight and should rest on the trigger guard.
- Only use the kind of projectiles suitable for your weapon.
- Always keep the muzzle pointed in a safe direction.
- This weapon may only be discharged in your own house, on authorized shooting ranges and inside enclosed private property. It is to be made sure that no projectile can leave the enclosed property.
- Keep the danger area of the projectile in mind.
- Never transport a loaded weapon. Only load your weapon when you intend to fire it.
- Never aim your airgun at persons or animals. Avoid ricochets. Never fire at smooth, hard surfaces or water.
- Before you discharge your weapon, make sure that target and surrounding area are safe.
- Make sure that you always have full control over the muzzle of your weapon, even if you stumble or fall down.
- Safety shooting glasses should always be worn when firing the weapon.
- Always store your weapon in a safe place and in unloaded condition. Unauthorized persons (persons not familiar with the use of weapons, children) must not have access to it. Ammunition is to be kept in a separate place.
- This weapon and its instruction manual may only be passed on to persons
 - who are fully familiar with its use and
 - who have reached the legally stipulated minimum age in the respective country.
- Modifications or repairs of weapons are only to be effected by authorized agencies or by a skilled gunsmith.
- Never leave a loaded weapon unattended.
- Only unloaded weapons are to be handed over to another person.

REPAIR

A gun that does not work properly is dangerous. Repairing a gun by oneself is difficult and an incorrectly assembled gun can malfunction in dangerous ways.

Caution: Repairs should only be completed by UMAREX authorized centres.



SAFETY INSTRUCTIONS | WARRANTY

CAUTION

For your own safety and the safety of others, carefully read these instructions before using this weapon. Buyers and owners must observe all rules concerning the use and ownership of air guns. Modifying this weapon may result in a change of its classification under weapons law and is therefore prohibited. In such cases the manufacturer's warranty will immediately become void.

WARNING

Do not brandish or display this airgun in public - it may confuse people and may be a crime. Police and others may think this airgun is a firearm. Do not change the coloration and markings to make it look more like a firearm. That is dangerous and may be a crime.

WARRANTY

During the legal warranty period, which begins on the date of purchase, UMAREX will repair or replace your weapon at no charge provided the defect was not caused by you. Return your weapon to an authorized dealer along with a description of the problem and proof of purchase.

The air guns manufactured by UMAREX Sportwaffen GmbH & Co. KG are made according to the regulations of the PTB (Physikalisch-Technische Bundesanstalt), German federal law, the CIP regulations and the technical know-how of UMAREX Sportwaffen GmbH & Co. KG.

We will not assume any liability whatsoever if this product is exported to territories outside of Germany and as a consequence does not comply with domestic legal requirements of these territories. It will be the sole responsibility of the importer to ensure compliance with local laws and regulations.

TECHNICAL DATA

Item no.	2.5982	2.5982X
	MP5K	
System	Gas Airsoft	
Caliber/Ammo	cal. 6 mm BB	
Energy	1,0 JOULE max.	
Velocity	up to 95 m/s with 0,20 g BB	
Drive	Semi-Auto	Semi + Full-Auto
Colour	Black	
Rate of fire	-	780 rate/min
Barrel length	140 mm	
Weight	2280 g	
max. Length	320 mm	
Magazine capacity	30 BBs	
Danger Distance	100 m	



DESCRIPTION

EN

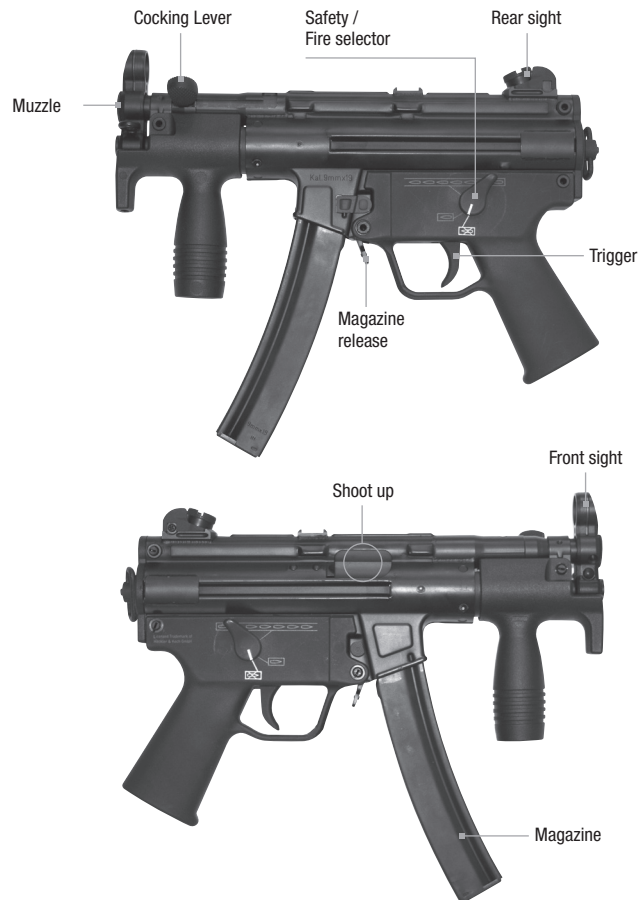



SAFETY / FIRE SELECTOR

EN

CAUTION

- Only handle your gun in its safe condition.
- Always make sure that the muzzle points in a safe direction.

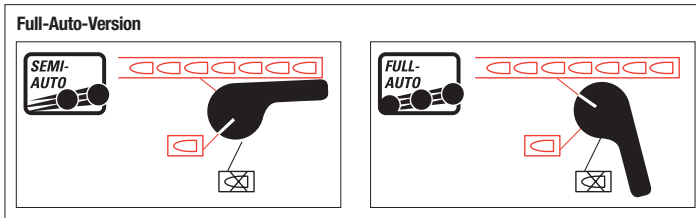

CAUTION

Please also always observe the legal regulations effective in your country for the use of arms.

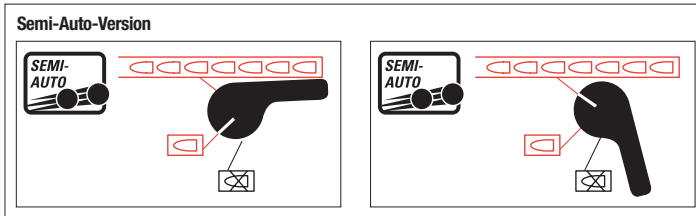

CAUTION

- Please do not switch the fire selector while pulling the trigger. This causes severe damage to your weapon.



PROBLEM SOLUTIONS



PROBLEMS

- Faulty shooting direction
- Weapon does not shoot
- Low shooting speed

POSSIBLE CAUSES

	Safety activated	Gas empty	Dirty barrel	Extreme temperatures	Wrong ammunition	Ammunition badly loaded	Weapon not cocked	Sight not properly adjusted
Faulty shooting direction			●	●	●	●		●
Weapon does not shoot	●	●			●	●	●	
Low shooting speed			●	●	●	●		



LOADING THE MAGAZINE

EN

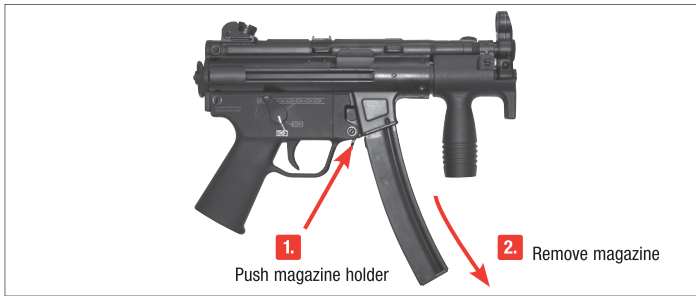

⚠ CAUTION

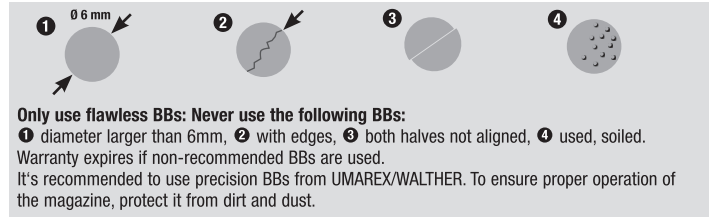



CHARGING OF GAS

⚠ CAUTION

- Keep hands and face at a safe distance from the escaping gas.
- Escaping gas may cause icing.
- Gas may explode if exposed to temperatures exceeding 50°C.
- Do not smoke, keep away from naked flames. The gas is highly inflammable.



Press the magazine holder.
Pull out the magazine.

NOTE

Keep the magazine with gas tank tilted. Attach the gas flask vertically to the charging port of the magazine. Press the flask against the port. The magazine is fully charged when you observe a discharge of gas from the port.



REMOVING OF GAS

Hold the magazine at its bottom. Press the valve Residual gas may now be discharged.



ADJUSTABLE REARSIGHT

EN

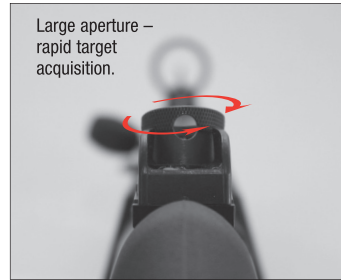

Large aperture –
rapid target
acquisition.



Small aperture –
precise shooting.



Loosen lug screws.



Turn.



Tighten the fixing
screw.

Windage adjustment



Shoot too far right:



Shoot too far left:

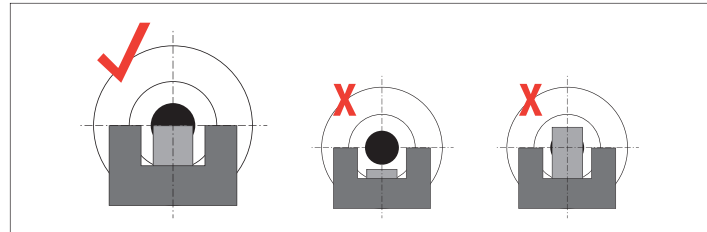



ADJUSTABLE SHOOT UP

EN

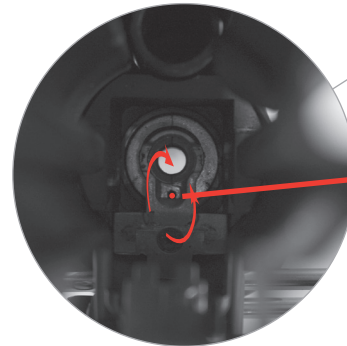
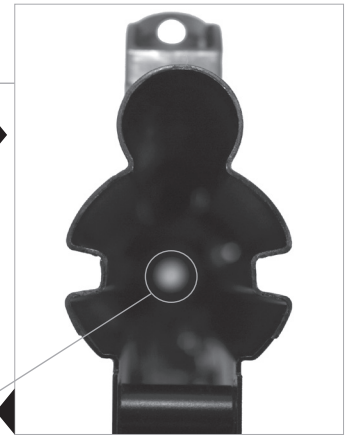
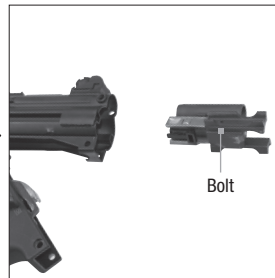
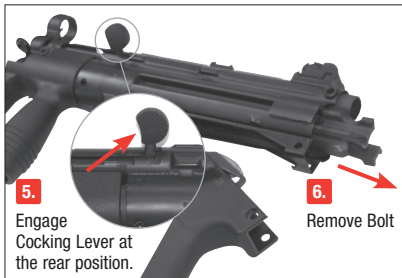
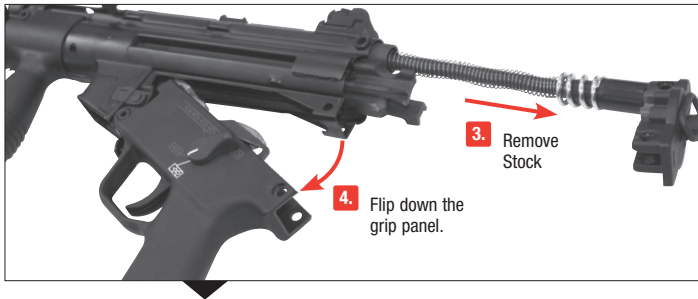

1.5 mm Allen key

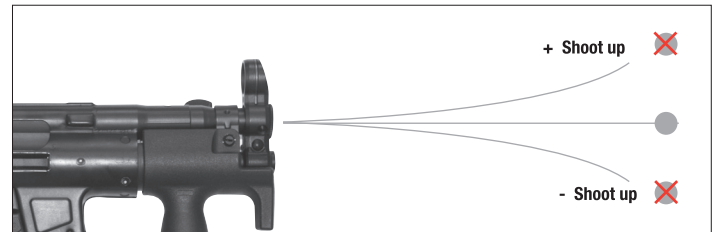



SHOOTING



BARREL CLEANING

EN

CAUTION

- Adjust the shoot up in normal position, before cleaning the weapon.
- Do not force the rod into the barrel, as this could cause damage.
- Occasionally clean the metal parts on the outside. Use a cloth which has been slightly dampened with some weapon oil.
- Never drip silicone oil directly into the barrel

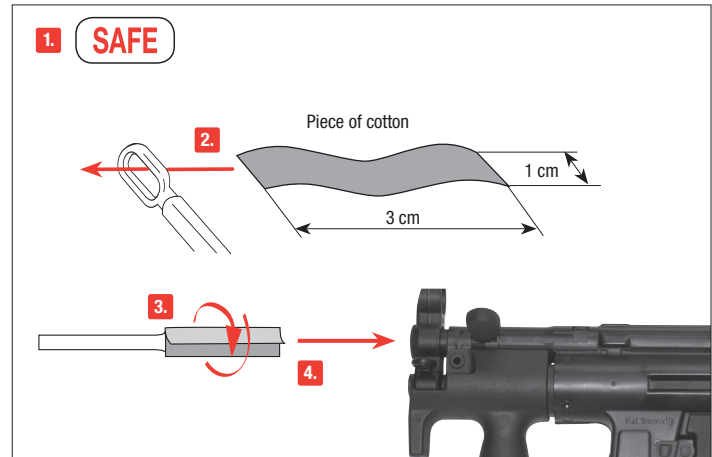

Put the safety on "safe". Prepare a thin rod with a length of approx. 30 cm. Attach a piece of cotton fabric to its end and clean the barrel with some silicone oil.



SICHERER UMGANG MIT WAFFEN

DE



BENENNUNG



BEDIENUNG



PFLEGE





SICHERHEITSHINWEISE

ACHTUNG

Der Kauf und der Besitz der vollautomatischen Ausführung Art. Nr. 2.5982X ist laut Waffengesetz in Deutschland verboten!

Sie sollten mit der richtigen, sicheren Handhabung Ihrer Waffe vertraut sein. Im Hinblick auf die Grundregeln zum sicheren Schießen bedenken Sie, dass jede Berührung mit der Waffe als Handhabung verstanden wird.

- Behandeln Sie jede Waffe so, als wäre sie geladen.
- Die Waffe beim Laden stets sichern, so dass sich kein Schuss ungewollt lösen kann. Finger immer außerhalb des Abzugsbügels halten und nur zum Schuss an den Abzug legen.
- Verwenden Sie nur für diese Waffe vorgesehene Geschosse.
- Halten Sie die Mündung stets in eine sichere Richtung.
- Das Schießen ist nur in der eigenen Wohnung, auf polizeilich zugelassenen Schießständen und im befriedeten Besitztum erlaubt, wenn das Geschoss dieses beim Schuss nicht verlassen kann. Hierbei den Gefahrenbereich des Geschosses beachten.
- Transportieren Sie niemals eine geladene Waffe. Laden Sie nur, wenn Sie schießen möchten.
- Waffe niemals auf Menschen oder Tiere richten. Vermeiden Sie Querschläger. Schießen Sie niemals auf glatte, harte Oberflächen oder auf Wasserflächen.
- Vergewissern Sie sich vor dem Schuss, dass Ziel und Umgebungsbereich sicher sind.
- Kontrollieren Sie immer, ob die Waffe ungeladen ist, wenn Sie sie transportieren oder von einer anderen Person übernehmen.
- Vergewissern Sie sich, dass Sie, auch beim Stolpern oder Stürzen die Richtung der Mündung kontrollieren können.
- Aus Sicherheitsgründen sollte beim Schießen eine Schutzbrille getragen werden.
- Aufbewahren der Waffe stets sicher und ungeladen vor unerlaubtem Zugriff Unbefugter (ungeschulte Personen, Kinder, Personen unter 18 Jahren) und getrennt von der Munition.
- Weitergabe dieser Waffe mit der Bedienungsanleitung nur an Personen
 - die mit der Handhabung dieser Waffe genauestens vertraut und bei Waffen mit -Zeichen mindestens 18 Jahre alt sind.
- Druckluftwaffen mit Energie > 0,5 Joule aber ohne -Zeichen sind erwerbscheinpflichtig.
- Jegliche Veränderungen oder Reparaturen von Waffen sollten nur von fachkundigen Firmen oder vom Büchsenmacher durchgeführt werden.
- Legen Sie niemals eine geladene Waffe aus der Hand.
- Geben Sie nur entladene Waffen an andere Personen weiter.

REPARATUR

Eine Waffe, die nicht einwandfrei funktioniert, ist gefährlich. Es ist schwierig, eine Waffe selbst zu reparieren, und falscher Zusammenbau kann zu gefährlichen Funktionsstörungen führen.

Achtung: Lassen Sie die Waffe nur von einem autorisiertem Fachhändler/ Büchsenmacher überprüfen und reparieren.



SICHERHEITSHINWEISE | GARANTIE

ACHTUNG

Zu Ihrer eigenen und zur Sicherheit anderer lesen Sie die Bedienungsanleitung vollständig und sorgfältig durch, bevor Sie mit der Waffe erstmalig hantieren. Käufer und Besitzer haben die Pflicht, alle Regeln über den Gebrauch und den Besitz von Druckluftwaffen zu befolgen. Jede Änderung an dieser Waffe kann zu einer Änderung der waffenrechtlichen Einstufung führen und ist somit unzulässig. Die Gewährleistung des Herstellers erlischt in diesem Fall sofort.

WARNUNG

Diese Druckluftwaffe nicht in der Öffentlichkeit zeigen oder mit ihr drohen – es führt zu Verwechselungen mit echten Waffen und gilt als Straftat. Ändern Sie keinesfalls die Farbe und Markierungen der Druckluftwaffe, um ihr Aussehen mehr einer realen Schusswaffe anzugleichen. Dies ist gefährlich und kann als Straftat gelten.

GARANTIE

Innerhalb des gesetzlich festgelegten Zeitraumes ab Kaufdatum repariert oder ersetzt Ihnen die Fa. UMAREX Ihre Waffe kostenlos, falls der Defekt nicht durch Eigenverschulden aufgetreten ist. Geben Sie die Waffe einem autorisierten Händler, beschreiben Sie ihm das Problem und fügen Sie den entsprechenden Kaufbeleg bei.

Die von UMAREX Sportwaffen GmbH & Co. KG hergestellten Druckluftwaffen werden gemäß den Zulassungsvorschriften der Physikalisch-Technischer Bundesanstalt (PTB), dem Bundesgesetz, den CIP-Vorschriften und dem waffentechnischen Know-how der Firma UMAREX Sportwaffen GmbH & Co. KG hergestellt.

Somit übernehmen wir keine Haftung, falls diese Ware nach dem Export ins Ausland nicht den dort geltenden Rechtsvorschriften entsprechen sollte und dem Besitzer/Käufer juristische Schwierigkeiten und Konsequenzen daraus entstehen sollten.

TECHNISCHE DATEN

Art. Nr.	2.5982	2.5982X
	MP5K	
System	Gas Airsoft	
Kaliber/Munition	cal. 6 mm BB	
Energie	1,0 JOULE max.	
Geschossgeschwindigkeit	bis 95 m/s mit 0,20 g BB	
Funktion	Semi-Auto	Voll-Auto
Farbe	Schwarz	
Kadenz	-	780 schuss/min
Lauflänge	140 mm	
Gewicht	2280 g	
max. Gesamtlänge	320 mm	
Magazinkapazität	30 BBs	
Gefahrenbereich max.	100 m	



BENENNUNG

DE





ACHTUNG

Hantieren Sie nur mit der Waffe, wenn diese gesichert ist. Achten Sie stets darauf, dass die Mündung in eine sichere Richtung zeigt.

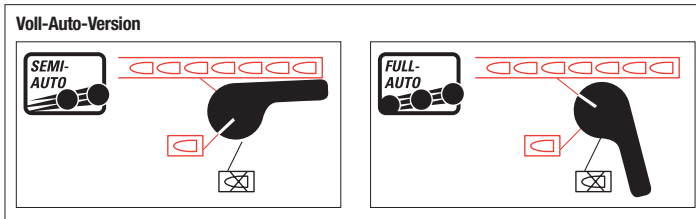

ACHTUNG

DE

In Deutschland werden die Waffen aus gesetzlichen Gründen nur als SEMIAUTO vertrieben. Bitte beachten Sie das jeweilige Waffengesetz in Ihrem Land.

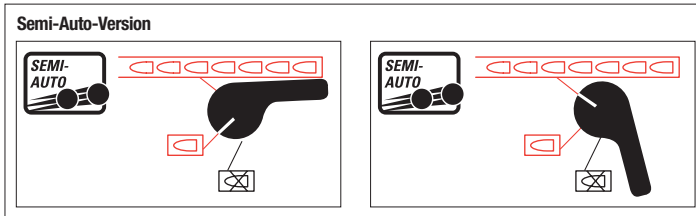

ACHTUNG

Schalten Sie niemals, während Sie den Abzug betätigen, den Feuerwahlhebel um. Dies verursacht schwere Schäden an Ihrer Waffe.



PROBLEMLÖSUNGEN



PROBLEME

schlechte Schussleistung
Waffe schießt nicht
geringe Geschwindigkeit

MÖGLICHE GRÜNDE

	Waffe gesichert	Kein Gas	Lauf verschmutzt	Extreme Temperaturen	Falsche Munition	Munition falsch geladen	Waffe nicht gespannt	Visierung nicht richtig eingesteilt
schlechte Schussleistung			●	●	●	●		●
Waffe schießt nicht	●	●			●	●	●	
geringe Geschwindigkeit			●	●	●	●		



MAGAZIN LADEN

DE

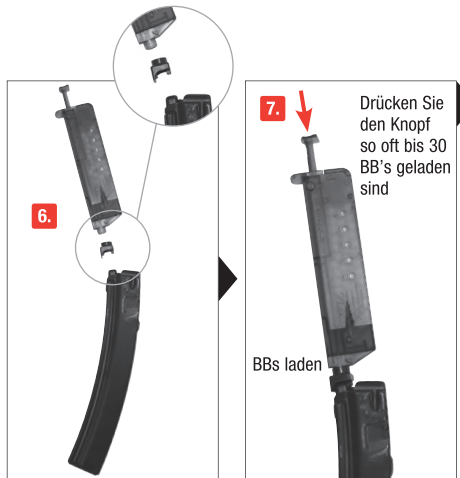
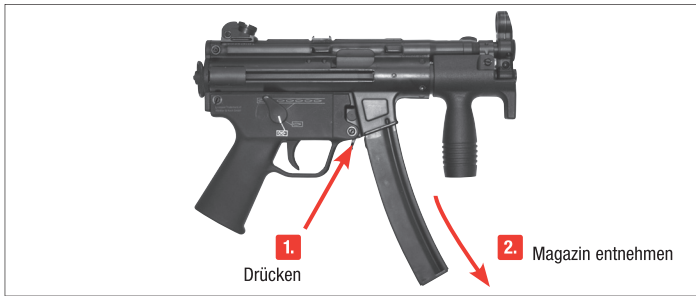

⚠️ ACHTUNG

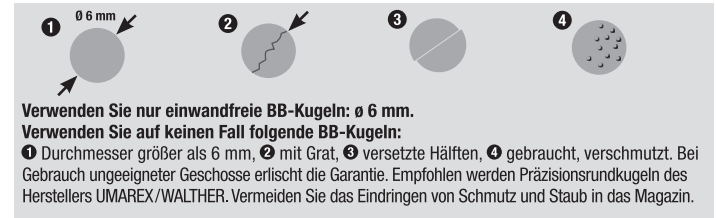

GAS EINFÜLLEN

ACHTUNG

- Gesicht und Hände in sicherem Abstand von dem entströmendem Gas halten.
- Entströmendes Gas kann Vereisungen verursachen.
- Gas keiner großen Hitze aussetzen, es kann ab 50°C explodieren.
- Nicht rauchen, kein offenes Feuer. Das Gas ist hochentzündlich.



HINWEIS

Halten Sie das Magazin mit Gastank nach unten geneigt. Stecken Sie die Gasflasche senkrecht in die Einfüllöffnung des Magazins. Drücken Sie die Gasflasche in die Einfüllöffnung. Wenn Gas aus der Einfüllöffnung entweicht, ist das Magazin mit Gas gefüllt.



VISIERUNG EINSTELLEN

DE

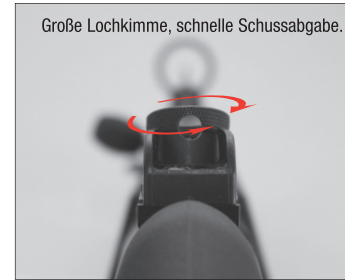

Fixierschraube lösen.



Drehen Sie die Fixierschraube wieder fest.

Seitenverstellung



Schuss zu weit rechts:



Schuss zu weit links:

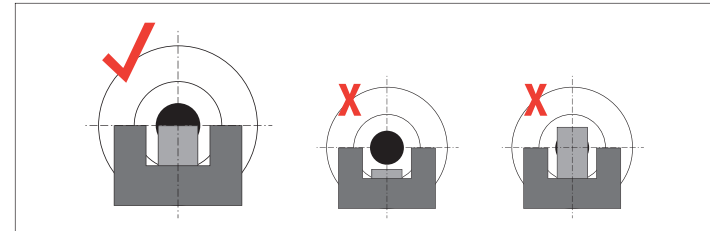



SHOOT UP EINSTELLEN

DE

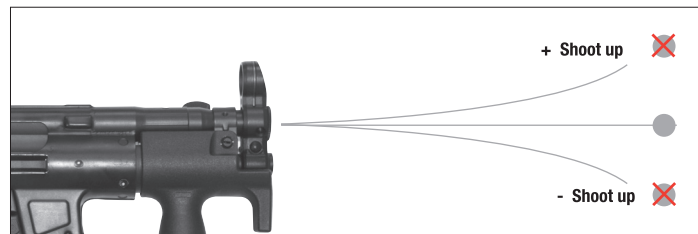
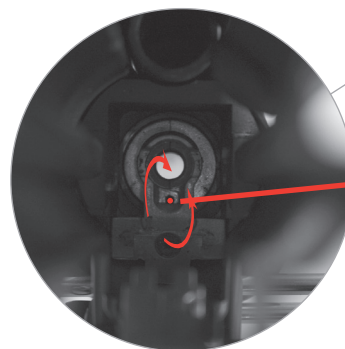
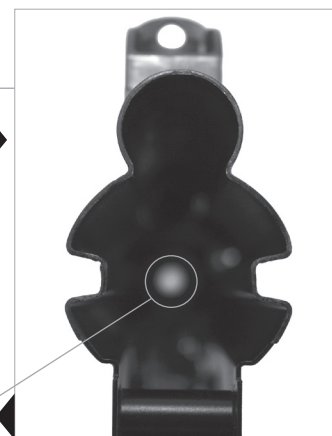
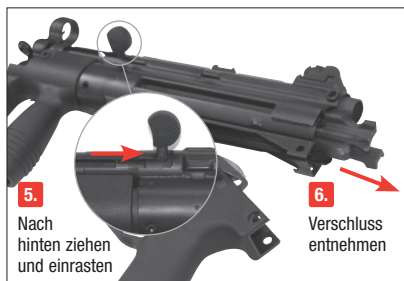
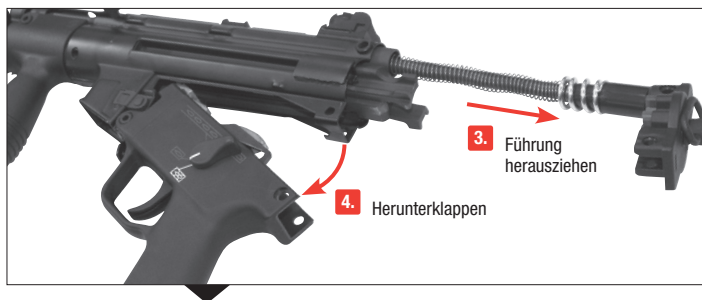
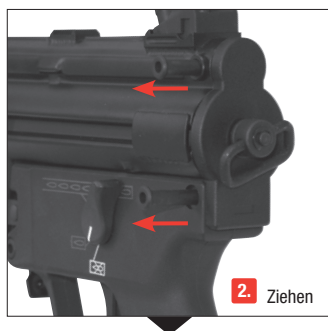



SCHIESSEN



LAUFREINIGUNG

DE

⚠️ ACHTUNG

- Vor dem Reinigen der Waffe das shoot up wieder auf Normal einstellen.
- Schieben Sie den Stab niemals mit Gewalt in den Lauf, dies kann Beschädigungen verursachen.
- Reinigen Sie gelegentlich die äußeren Metallteile. Benutzen Sie dazu ein Tuch, auf das Sie leicht Waffenöl aufgetragen haben.
- Geben Sie niemals das Waffen-Öl direkt in den Lauf.

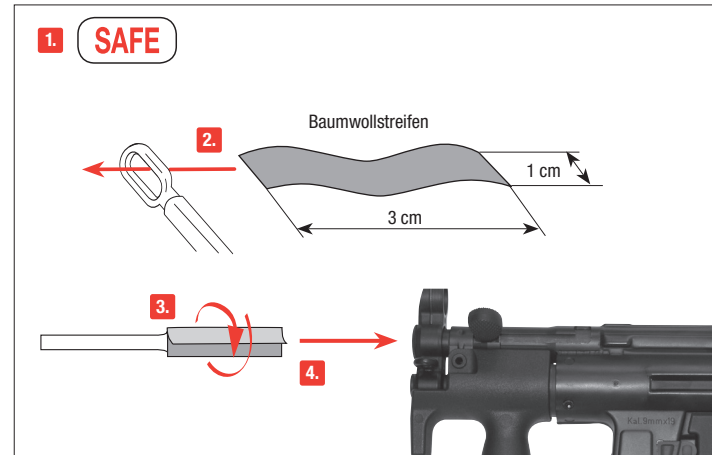

Sichern Sie die Waffe. Nehmen Sie einen ca. 30 cm dünnen, langen Stab. Wickeln Sie ein Stück Baumwolltuch um das Ende, benetzen Sie das Tuch mit etwas Waffen-Öl und reinigen Sie damit den Lauf.



MANIEMENT DES ARMES EN TOUTE SÉCURITÉ

FR



DESIGNATION



UTILISATION



ENTRETIEN



INSTRUCTIONS DE SÉCURITÉ

Vous devez savoir manier votre arme correctement et de manière sûre et devez impérativement respecter les règles de base de tir en toute sécurité à chaque fois que vous manipulez l'arme.

- Maniez toujours l'arme comme si elle était chargée.
- Mettez toujours la sûreté avant de charger l'arme afin d'éviter tout tir involontaire.
- Ne mettez pas le doigt sur la détente et ne l'y placez que lorsque vous allez tirer.
- N'utilisez que les projectiles prévus pour cette arme.
- Pointez toujours la bouche de l'arme dans une direction non dangereuse.
- Il n'est permis de tirer avec l'arme que sur le lieu de résidence du propriétaire ou dans des zones de tir autorisées par la police, à condition que le projectile ne puisse pas sortir de la zone de tir. Veuillez toujours prendre en compte la zone de danger maximale du projectile.
- Ne transportez jamais l'arme lorsqu'elle est chargée. Ne la chargez que lorsque vous vous apprêtez à tirer.
- Ne dirigez jamais l'arme vers des personnes ni des animaux. Évitez les tirs pouvant faire ricocher le projectile. Ne tirez jamais sur des surfaces planes et dures, ni sur une surface d'eau car les projectiles peuvent ricocher.
- Avant de tirer, assurez-vous que l'objectif et les alentours ne présentent pas de danger.
- Vérifiez toujours que l'arme est déchargée avant de la transporter ou de la remettre à autrui.
- Veillez à maîtriser la direction dans laquelle la bouche de l'arme est pointée, même si vous trébuchez ou tombez.
- Pour des raisons de sécurité, portez des lunettes de protection lorsque vous tirez.
- Rangez toujours l'arme déchargée, séparée des munitions et dans un endroit sûr afin d'éviter que des personnes non autorisées (personnes non formées, enfants) puissent y avoir accès.
- Ne remettez cette arme, accompagnée du mode d'emploi, qu'à des personnes
 - qui sont le plus possible formées au maniement de cette arme et
 - qui ont atteint l'âge minimum légal selon la loi sur les armes en vigueur dans votre pays.
- Toute modification ou réparation de l'arme devra être effectuée par une entreprise spécialisée ou un armurier.
- Ne laissez jamais l'arme chargée sans surveillance.
- Déchargez toujours l'arme avant de la remettre à autrui.

RÉPARATIONS

Une arme qui ne fonctionne pas parfaitement est dangereuse. Il est difficile de réparer une arme soi-même, et un remontage incorrect peut entraîner des dysfonctionnements dangereux.

Attention : seules des personnes spécialisées agréées ou un armurier peuvent contrôler et réparer l'arme.

Cette boîte contient: une réplique d'arme factice avec chargeur. Les AIRSOFT GUNS sont des modèles d'armes factices tirant des billes en plastique de 6 mm inoffensives. Ce modèle a une énergie comprise entre 0,08 joule et inférieure ou égale à 2 joules. En France, la vente de ces produits est réglementée par le décret n°99-240 du 24 mars 1999, qui interdit la distribution des modèles noirs ou chromés dont l'énergie est comprise entre 0,08 et 2 joules aux moins de 18 ans non accompagnés. Ce décret ne concerne pas les modèles transparents, les game guns (oranges) et les mini guns, dont la distribution reste donc autorisée aux mineurs.

- Distribution et vente interdite aux mineurs. • Attention: Ne jamais diriger le tir vers une personne.



CONSIGNES DE SÉCURITÉ | GARANTIE



ATTENTION

Pour votre sécurité et celle d'autrui, lisez attentivement la notice d'emploi avant d'utiliser l'arme pour la première fois. Les vendeurs, tout comme les acheteurs, ont l'obligation de respecter le règlement relatif à l'utilisation et à la possession d'armes à air comprimé. Il est interdit de procéder à toute modification de ce pistolet car cela pourrait entraîner un changement dans la classification correspondant à la législation sur les armes à feu. De plus, toute modification entraînerait l'annulation immédiate de la garantie du fabricant.



MISE EN GARDE

Mise en garde: N'exhibez pas cette arme à air comprimé et ne la sortez pas en public. Cela pourrait prêter à confusion ou être considéré comme un délit. Les membres des forces de sécurité et la police pourraient la prendre pour une vraie arme à feu. Ne changez pas sa couleur ni les éléments d'identification pour qu'elle ressemble plus à une vraie arme à feu. Cela serait dangereux et peut être considéré comme un délit.

GARANTIE

La société UMAREX s'engage à réparer ou à remplacer votre arme durant une période déterminée légalement à compter de la date d'achat, à condition que vous ne soyez pas responsable du défaut. Pour cela, remettez l'arme à un revendeur autorisé, décrivez-lui le problème et joignez le justificatif d'achat correspondant.

Les armes à air comprimé de la société UMAREX Sportwaffen GmbH & Co. KG sont fabriquées conformément aux directives de conformité de l'institut allemand « Physikalisch-Technische Bundesanstalt (PTB) », à la loi fédérale, aux prescriptions CIP et au savoir-faire technique de la société UMAREX Sportwaffen GmbH & Co. KG dans le domaine des armes.

Ainsi, nous ne pouvons être tenus responsables si, après exportation à l'étranger, cette marchandise ne répond pas aux prescriptions légales en vigueur dans le pays en question et si le possesseur/acheteur doit pour cette raison faire face à des difficultés juridiques ou toute autre conséquence pouvant découler de ce fait.

DONNÉES TECHNIQUES

Numéro d'article	2.5982	2.5982X
	MP5K	
Système	Airssoft gaz	
Calibre / Munitions	Billes BB cal. 6 mm	
Énergie	1,0 JOULE max.	
Vitesse	jusque 95 m/s avec billes BB 0,20 g	
Action	Semi-Auto	Semi + Full-Auto
Couleur	Noir	
Cadence	-	780 tir/min
Longueur canon	140 mm	
Poids	2280 g	
Longueur	320 mm	
Capacité du chargeur	30 BBs	
Zone de danger	100 m	

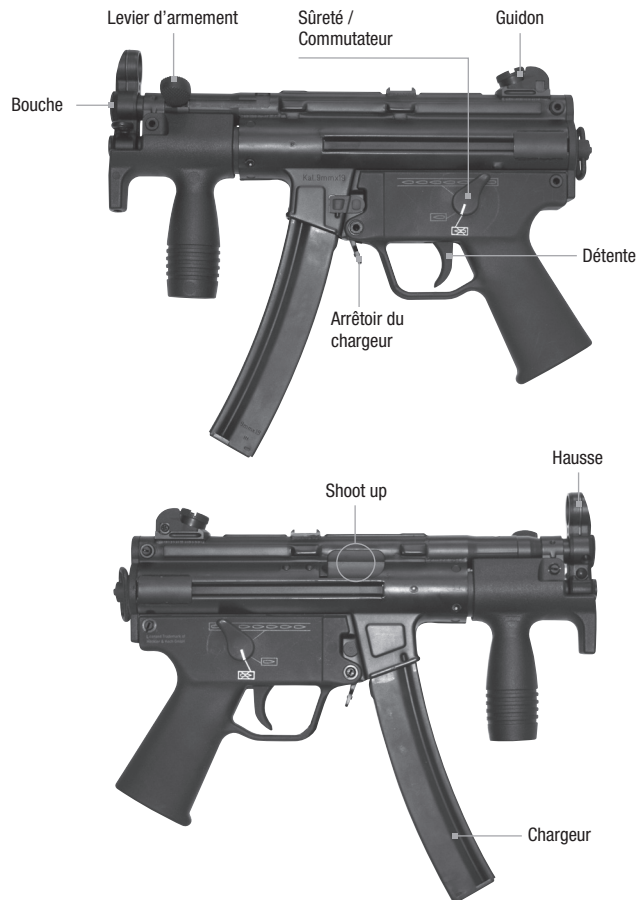

DÉSIGNATION DES PIÈCES

FR

 **ATTENTION**

- Ne manipulez l'arme que lorsque la sûreté est enclenchée.
- Assurez-vous que la bouche est orientée dans une direction non dangereuse.

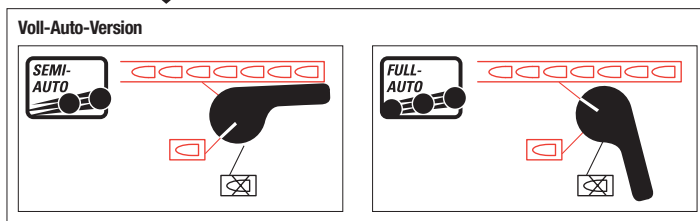

 **ATTENTION**

Veillez à respecter la législation sur les armes en vigueur dans votre pays !

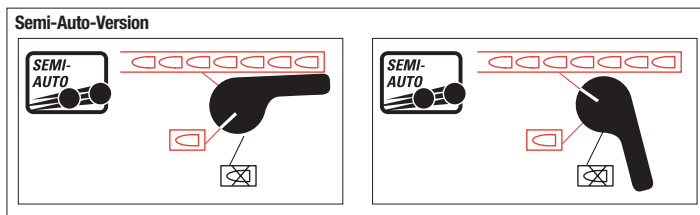

 **ATTENTION**

- N'actionnez jamais le commutateur pendant que vous appuyez sur la détente. Cela entraîne de graves dommages.

 **DYSFONCTIONNEMENTS**



DYSFONCTIONNEMENTS

- Mauvaise performance de tir
- l'arme ne tire pas
- Faible vitesse du projectile

CAUSES POSSIBLES

	sûreté de l'arme enclenchée	gaz vide	canon encrassé	températures extrêmes	mauvaises munitions	munitions mal chargées	l'arme n'est pas tendu	dispositif de visée mal réglé
Mauvaise performance de tir			●	●	●	●		●
l'arme ne tire pas	●	●			●	●	●	
Faible vitesse du projectile			●	●	●	●		



CHARGEMENT BB

FR

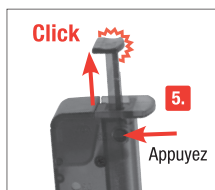
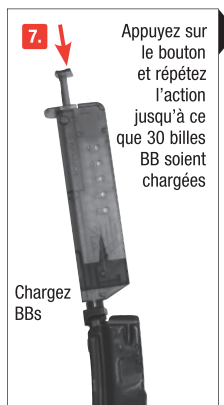
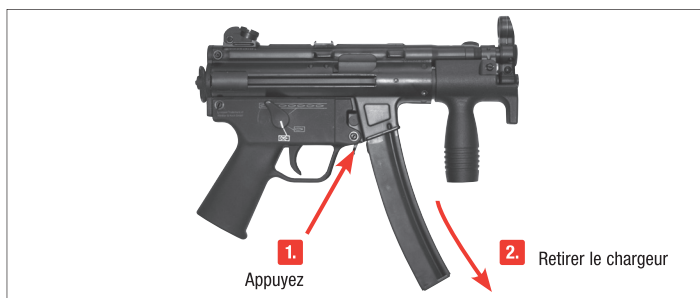

⚠ ATTENTION

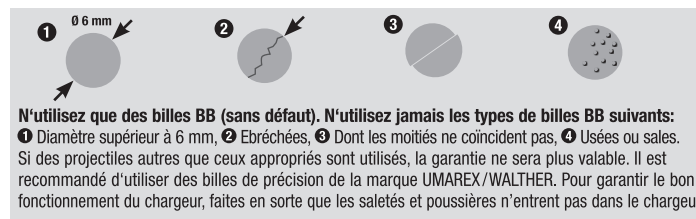



CHARGEMENT DU GAZ

⚠ ATTENTION

- Maintenez la bonbonne de gaz à une distance raisonnable de votre visage et de vos mains.
- Les éventuelles fuites de peuvent provoquer une engelure.
- Ne les exposez pas à une chaleur excessive et ne les conservez pas à des températures supérieures à 50 °C.
- Ne fumez pas et tenez-vous loin de toute flamme. Le gaz est hautement inflammable.



Appuyez sur l'arrêt du chargeur. Retirez le chargeur du pistolet par la partie inférieure de la poignée.

REMARQUE

Maintenez le chargeur pour gaz tank incliné vers le bas. Introduisez l'embouchure de la bonbonne de gaz dans l'ouverture du chargeur en position verticale. Enfoncez la bonbonne de gaz dans l'ouverture du chargeur. Lorsque le gaz s'échappe par les côtés de l'ouverture du chargeur, cela signifie que le chargeur est plein.



AJUSTAGE LA HAUSSE

FR

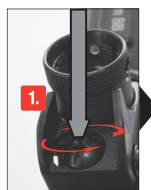

Dévisser les vis de fixation.

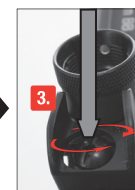

Serrez à nouveau la vis de fixation.

Ajustage de latéral



trop à gauche :



trop à droite :

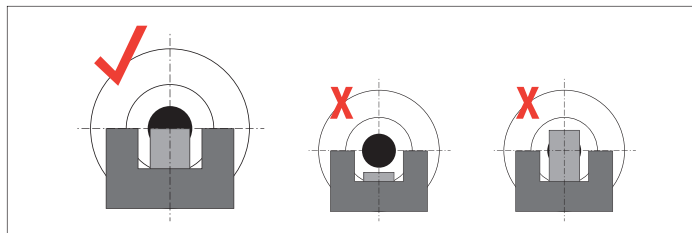

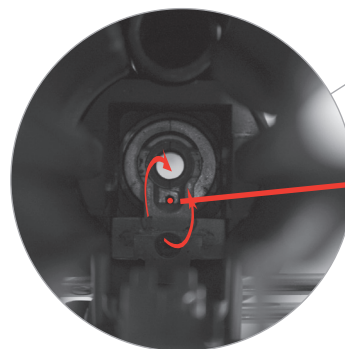
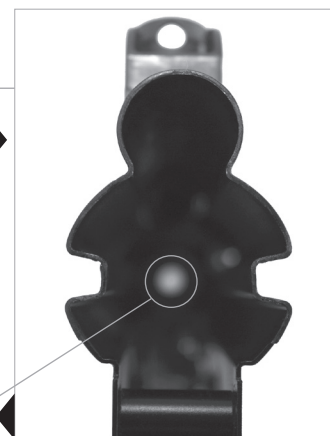
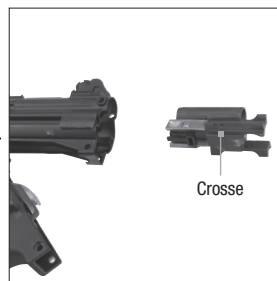
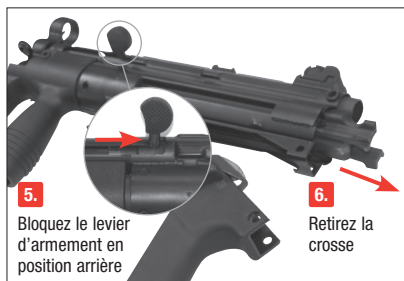
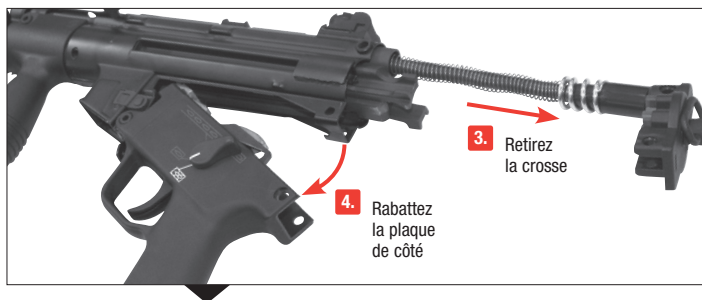
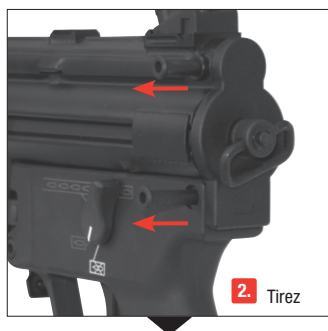

Clé mâle à six pans 1,5 mm

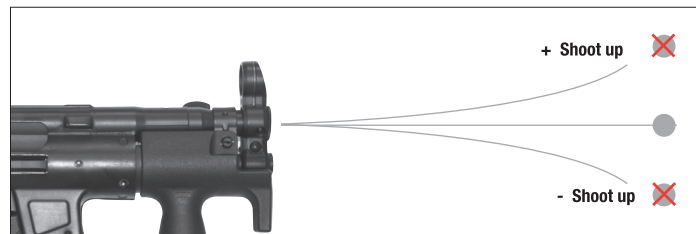

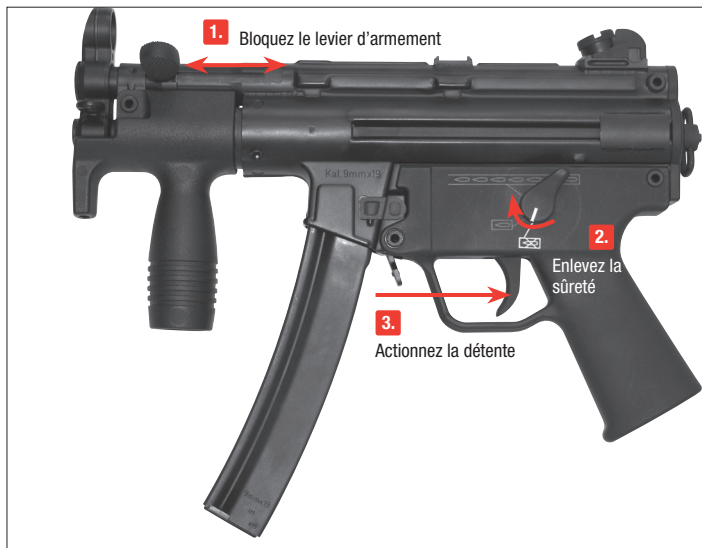
**ATTENTION**

- Reajuster le „shoot up“ à „Normal“ avant de nettoyer l'arme.
- N'enfoncez pas la baguette de nettoyage violemment dans le canon, car elle pourrait l'endommager.
- Nettoyez les pièces métalliques extérieures à l'aide d'un chiffon doux préalablement imbibé d'huile pour armes.
- Ne versez jamais l'huile de silicone directement dans le canon.

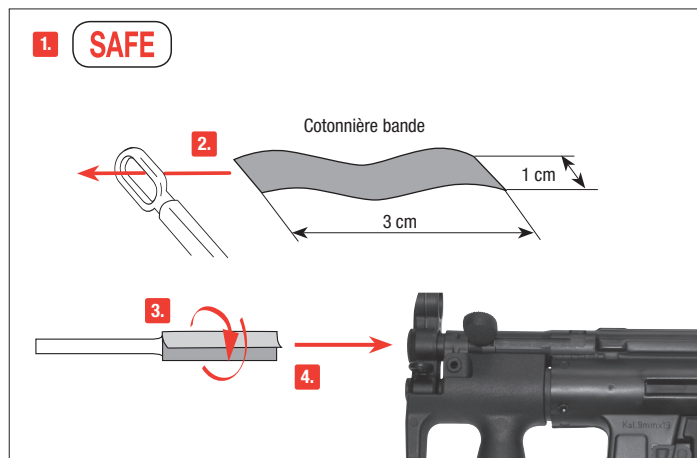

Mettez la sûreté de l'arme. Utilisez une tige fine d'une longueur d'env. 30 cm. Enroulez une bandelette de coton à son extrémité et nettoyez le canon avec une petite quantité d'huile de silicone.



MANEJO SEGURO DE ARMAS

ES



DESIGNACION



REGLAJE



CUIDADOS



INSTRUCCIONES DE SEGURIDAD

Deberá estar familiarizado con el manejo correcto y seguro de su arma. Con respecto a las reglas básicas para disparar con seguridad, considere cada contacto con el arma como parte de su manejo.

- Trate el arma como si siempre estuviera cargada.
- Cargue siempre el arma con el seguro activado para evitar disparos involuntarios.
- Mantenga el dedo siempre fuera del gatillo y colóquelo solamente cuando vaya a disparar.
- Utilice únicamente proyectiles específicos para esta arma.
- Mantenga la boca del arma siempre en una dirección segura.
- Sólo está permitido disparar el arma en la vivienda del propietario o en las zonas de tiro autorizadas por la policía, siempre y cuando el proyectil no pueda llegar más allá del área de tiro. Para ello, tenga presente siempre la distancia máxima de peligro del proyectil.
- Nunca transporte el arma cargada. Cárguela solamente cuando tenga intención de disparar.
- Nunca apunte con el arma hacia personas o animales. Evite los disparos en los que el proyectil pueda rebotar: nunca dispare sobre superficies lisas y duras, ni al agua.
- Antes de disparar, asegúrese de que el objetivo y el entorno sean seguros.
- Antes de transportar el arma o de recibirla de manos de otra persona compruebe siempre que está descargada.
- Asegúrese de poder controlar la dirección hacia la que apunta la boca, aún en caso de tropiezo o de caída del arma.
- Por motivos de seguridad, cuando vaya a disparar póngase siempre gafas protectoras.
- Guarde el arma siempre descargada, separada de la munición y en lugar seguro para evitar que personas no aptas (personas sin formación, niños) puedan acceder a ella.
- Entregue esta arma, junto con las instrucciones de uso, únicamente a aquellas personas que:
 - estén perfectamente familiarizadas con el manejo de esta arma
 - hayan cumplido la edad mínima correspondiente fijada por la legislación en materia de armas del país respectivo.
- Cualquier modificación o reparación del arma deberá llevarla a cabo una empresa especializada o un armero.
- Nunca deje sin vigilancia un arma cargada.
- Siempre que entregue un arma a otra persona, asegúrese de que está descargada.

REPARACIONES

Una arma que no funcione perfectamente es peligrosa. Es difícil reparar uno mismo un arma, y un ensamblaje incorrecto puede producir anomalías de funcionamiento peligrosas.

Atención: La comprobación y reparación del arma sólo pueden llevarla a cabo especialistas autorizados o un armero.



INSTRUCCIONES DE SEGURIDAD | GARANTIA



DESIGNACION

ES

ATENCIÓN

Por su propia seguridad y la de los demás, lea detenidamente las instrucciones de uso antes de disparar el arma por primera vez. Vendedores y compradores están obligados a cumplir con las normas de uso y posesión de armas de aire comprimido. Queda prohibida cualquier modificación de esta arma, ya que ello podría implicar un cambio en su clasificación legal. En caso de modificación quedaría extinguida de inmediato la garantía del fabricante.

AVISO

No porte o muestre este arma de aire comprimido en público. Puede ser motivo de confusiones e ilegal. Miembros de las fuerzas de seguridad y la policía pueden tomarla por un arma de fuego real. No modifique el color ni los elementos identificativos para hacer que se parezca más a un arma de fuego real. Es peligroso y puede ser un delito

GARANTIA

La empresa UMAREX se responsabiliza de reparar o sustituir su producto sin coste alguno en el plazo legalmente fijado a partir de la fecha de compra, siempre que el defecto no sea responsabilidad del propio usuario. Entregue el arma a un comerciante autorizado, describale el problema y adjunte el correspondiente comprobante de compra.

Las armas de aire comprimido de la empresa UMAREX Sportwaffen GmbH & Co. KG se fabrican de conformidad con las normas de homologación del Instituto Federal PTB (Physikalisch-Technischer Bundesanstalt), con la Ley Federal alemana, la normativa que establece el centro CIP y la experiencia en fabricación de armas de UMAREX Sportwaffen GmbH & Co. KG.

Por eso, no asumimos ninguna responsabilidad en el caso de que al exportar el arma a un país extranjero, ésta no cumpliera con la normativa legal local y el propietario o comprador tuviera que responder jurídicamente por dicho incumplimiento.

DATOS TÉCNICOS

Número de artículo	2.5982 	2.5982X
	MP5K	
Sistema	Gas Airsoft	
Calibre/munición	cal. 6 mm BB	
Energía	1,0 JOULE max.	
Velocidad de disparo	hasta 95 m/s con BB 0,20 g	
Función	Semi-Auto	Semi + Full-Auto
Color	Negro	
Cadencia	-	780 tiros/min
Longitud del cañón	140 mm	
Peso	2280 g	
Longitud	320 mm	
Capacidad del cargador	30 BBs	
Distancia de peligro	100 m	

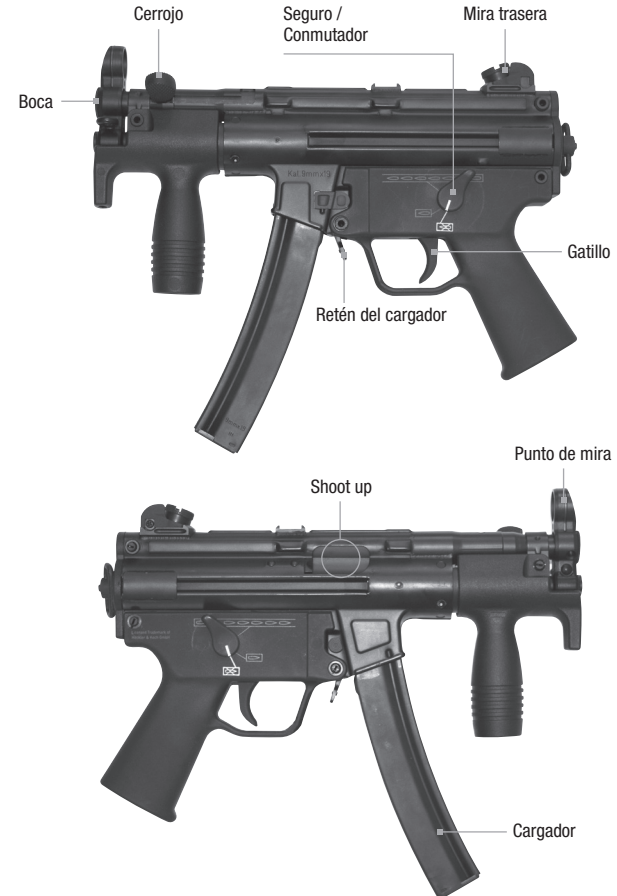

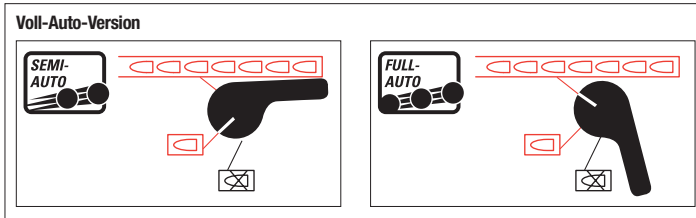

ATENCIÓN

- Manipule el arma sólo cuando con el seguro activado.
- Procure que la boca apunte siempre en una dirección segura.

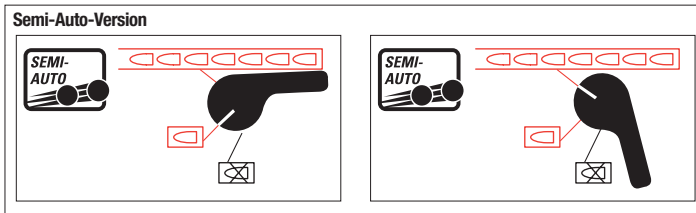

ATENCIÓN

Rogamos observe en todo caso la legislación vigente en su país sobre el uso de armas.



ATENCIÓN

- Durante implicar el gatillo nunca conmute el conmutador. Esto causa daños graves.

PROBLEMAS

PROBLEMAS

- Potencia de disparo deficiente
- El arma no dispara
- Escasa velocidad de disparo

POSIBLES CAUSAS

	Seguro activado	Gas vacío	Cañón sucio	Temperaturas extremas	Munición errónea	Munición mal cargada	El arma no está armatillada	La mira no está bien ajustada
Potencia de disparo deficiente			●	●	●	●		●
El arma no dispara	●	●			●	●	●	
Escasa velocidad de disparo			●	●	●	●		



CARGA DEL CARGADOR

ES

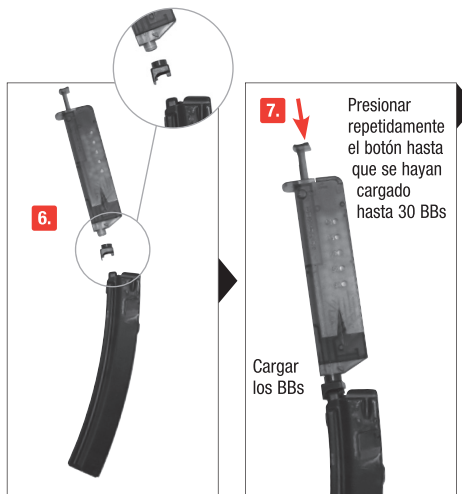
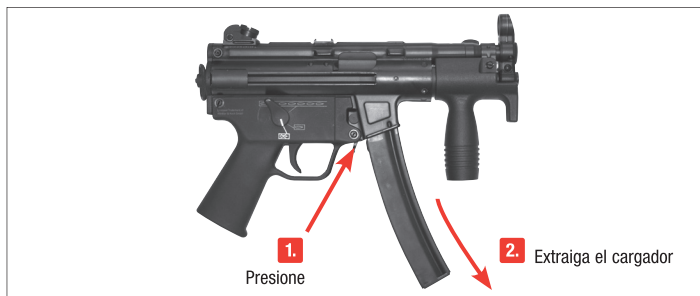

⚠️ ATENCIÓN

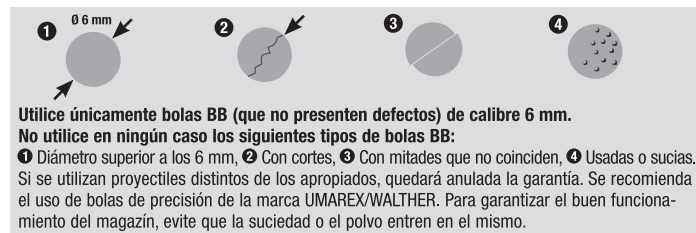



CARGA DEL GAS

⚠ ATENCIÓN

- Mantenga la cara y las manos a una distancia prudente de el gas.
- Las posibles fugas de pueden causar congelación.
- El gas pueden explotar a partir de los 50 °C.
- No fume y manténgase alejado de cualquier fuego. El gas es altamente inflamable.



Presione el retén del cargador. Extraiga el cargador de la pistola por la parte inferior de la empuñadura.

NOTA

Mantenga el cargador en gas el tanque inclinado hacia abajo. Introduzca la boquilla de la bombona de gas en la abertura del cargador en posición vertical. Apriete la bombona de gas en la abertura de carga. Cuando el gas se escape por los laterales de la abertura de carga significará que el cargador está lleno.

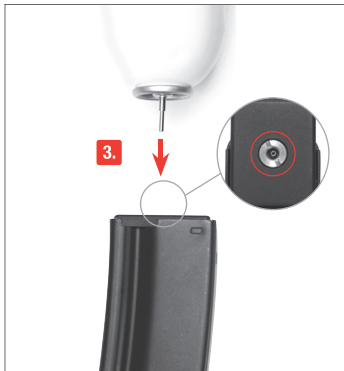

EXTIRPAR DEL GAS

Sujete el cargador hacia abajo. Presione la válvula y desplace el seguro de la válvula hacia arriba. El gas restante se saldrá del cargador.



AJUSTE DE MIRA

ES

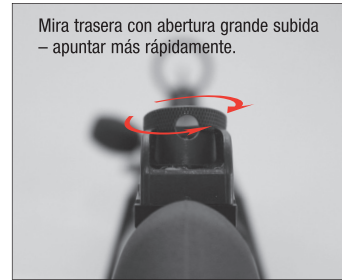

Desatornillar los tornillos de fijación.



Vuelva a asegurar el tornillo de sujeción.

Mira trasera ajuste en deriva



Demasiado hacia la derecha:



Demasiado hacia la izquierda:

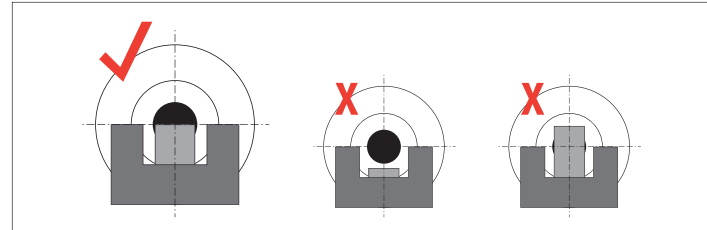

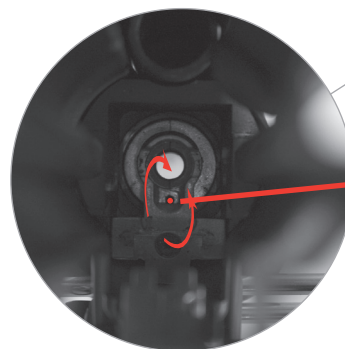
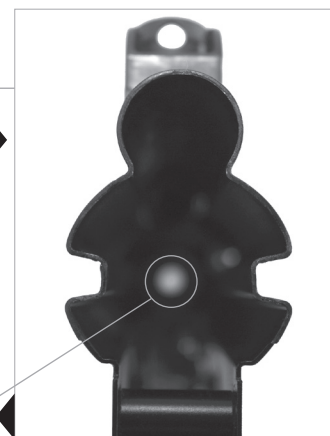
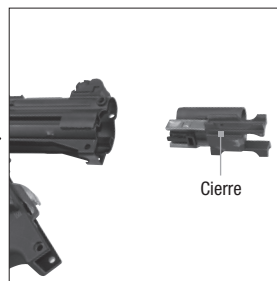

Llave Allen 1,5 mm

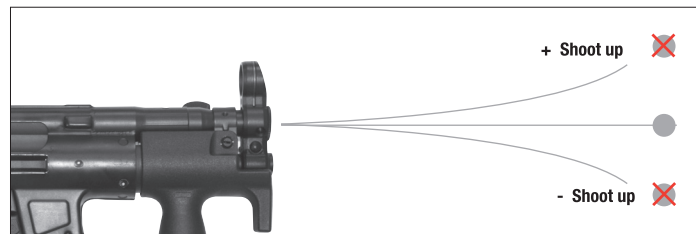



DISPARAR



LA LIMPIEZA DE CAÑÓN

ES

⚠️ ATENCIÓN

- Reajustar el „shoot up“ a „Normal“ antes limpiar el arma.
- No debe forzar la varilla de limpieza para introducirla dentro del cañón, porque podría dañar el arma.
- Limpie las piezas metálicas exteriores con un trapo suave, humedecido con aceite para armas.
- No vierta nunca aceite de silicona directamente dentro del cañón.

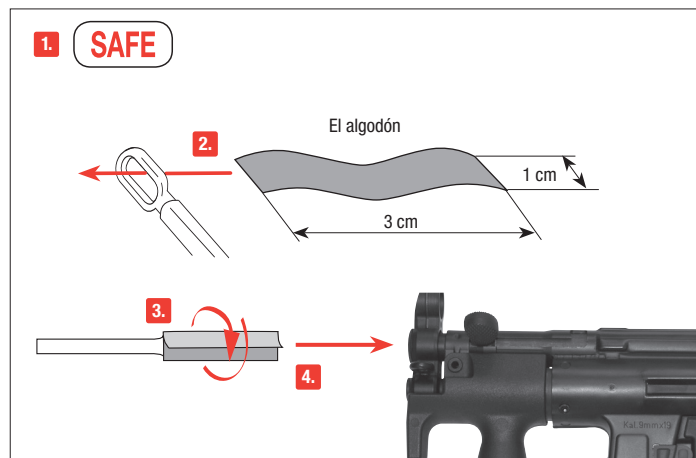

Asegure el arma. Coja una barra estrecha y larga de unos 60 cm. Enrole un paño de algodón por el extremo, humedézcalo con un poco de aceite para armas y limpie el cañón con ayuda del mismo.

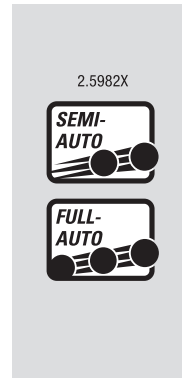
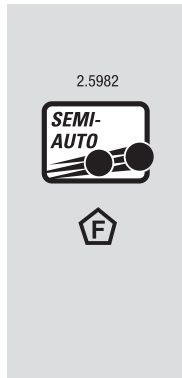

UMAREX®

UMAREX Sportwaffen GmbH + Co. KG

P.O. Box 27 20

D-59717 Arnsberg | Germany

Phone: +49 29 32 / 638-01

Fax: +49 29 32 / 638-222

verkauf@umarex.de | sales@umarex.de

www.umarex.com

We reserve the right to make color and design changes and technical improvements. No responsibility is accepted for printing errors or incorrect information.

Änderungen in Farbe und Design, sowie technische Verbesserungen, Druckfehler und Irrtum vorbehalten. Alle Angaben ohne Gewähr.

Sauf modifications de la couleur et du design ainsi que des améliorations techniques, erreurs d'impression et erreur. Toutes les données sont fournies sans garantie.

Salvo modificaciones de color y de diseño así como mejoramientos técnicos, erratas y error. Todos los datos sin garantía.

© UMAREX Sportwaffen GmbH + Co. KG